



Bill Acceptor

XBA-mini

Installation Guide

Use of Materials Limitations

International Currency Technologies Corporation (ICT) all rights reserved.

All materials contained are the copyrighted property of ICT.

All trademarks, service marks, and trade names are proprietary to ICT.

ICT reserves the right at all times to disclose or to modify any information as ICT deems necessary to satisfy any applicable law, regulation, legal process or governmental request, or to edit, refuse to post or to remove any information or materials, in whole or in part, in ICT's sole discretion.

Contents

1. Introduction	
1-1. Overview	2
1-2. Features	2
2. Specifications	2
3. Packing List	4
4. Dimension	4
5. Installation	
5-1. Harness Application	6
5-1-1. I/O Circuit	12
5-2. DIP Switch Setting	16
5-3. Software Download and Upgrade	16
6. Maintenance	17
7. Troubleshooting	
7-1. Bezel LED Errors.....	18
7-2. Back LED Errors.....	19

1. Introduction

1-1. Overview

The XBA-mini Bill Acceptor equips with innovative wide-angle banknote insertion technology to offer superior acceptance rate of 98% or higher. With the outstanding design, the XBA-mini has the ability to provide very high degree of immunity to strong ambient light, and the advanced optical/mechanical anti-fishing structure for better investment protection. The built-in USB port allows firmware upgrades via USB flash drive conveniently.

1-2. Features

- Unique wide-angle banknote insertion technology
- High immunity against strong ambient light
- Advanced optical/mechanical anti-fishing structure
- Firmware via USB, MDB-FTL, TTL-Serial.
- Auto-calibration technology and multi-color optical sensors
- Superior validation M.T.B.F 300.000 cycles
- Strong resistance to severe weather conditions
- Improved water draining system
- Equipped with flip-up metal cash box

2. Specifications

General

Acceptance Rate	98% or greater
<i>Note: The incomplete bills such as extremely dirty, wet, broken or wrinkled ones are excluded.</i>	
Bill Insertion	Four way acceptable
Transaction Speed	Approx. 2.5s to stack
Interface	Pulse MDB ICT Protocol JPSTD
Installation	Indoor & Outdoor

Electrical

Power Source	12V DC±10% 24V DC±10% 24V/34V DC±10% 24V AC±10%
Power Consumption	Standby: 0.2A, 2.4W Operation: 1.0A, 12W Maximum: 2.0A, 24W
Operation Environment	Operating Temperature: -15°C~60°C Storage Temperature: -30°C~70°C Humidity: 30%~95%RH(no condensation)

Mechanical

Bill Capacity	Standard cashbox: Approx.100 bills, 200 bills, 350 bills, 600 bills, 1000 bills. Flip-up cashbox: Approx.100 bills, 200 bills. Extended cashbox: Approx.400 bills, 600 bills, 1000 bills.
----------------------	---

Weight	Approx. 1.2kg~1.7kg (Depend on Bezel style and Bill box capacity)
Bill Accepted Width	Standard/ Extended cashbox: 62~74mm Flip-up cashbox: 62~72mm
Bill Accepted Length	Standard/ Flip-up cashbox: 120~160mm Extended cashbox: 120~180mm

3. Packing List

Main	Bill Acceptor
Accessory	Harnesses: Refer to 5-1

4. Dimension

< Standard cashbox >

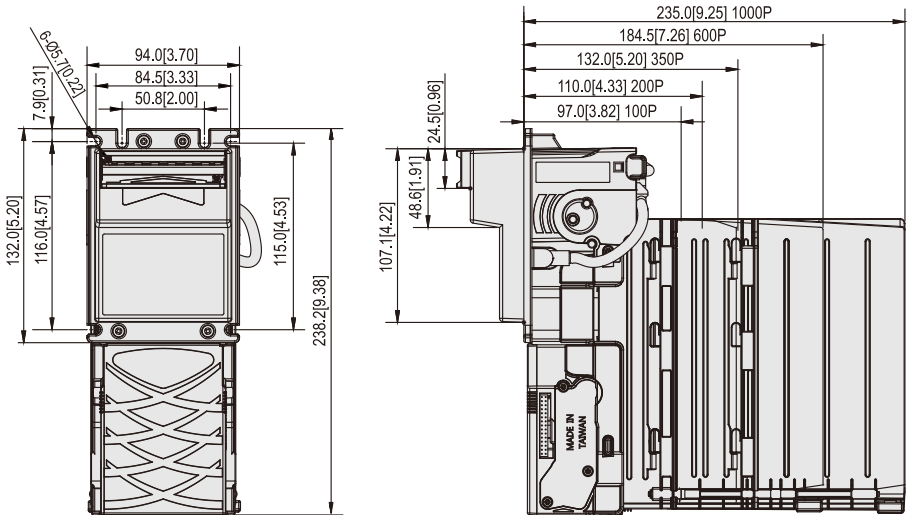

Unit : mm [inch]

4 FIG.01

< Flip-up cashbox >

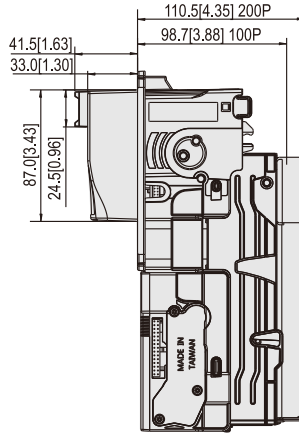
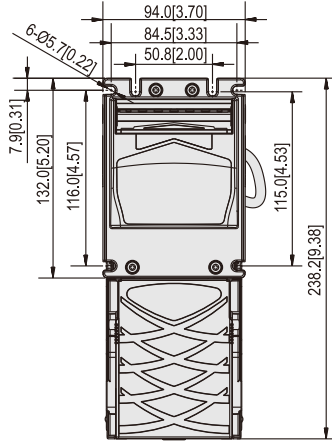

Unit : mm [inch]

4 FIG.02

< Extended cashbox >

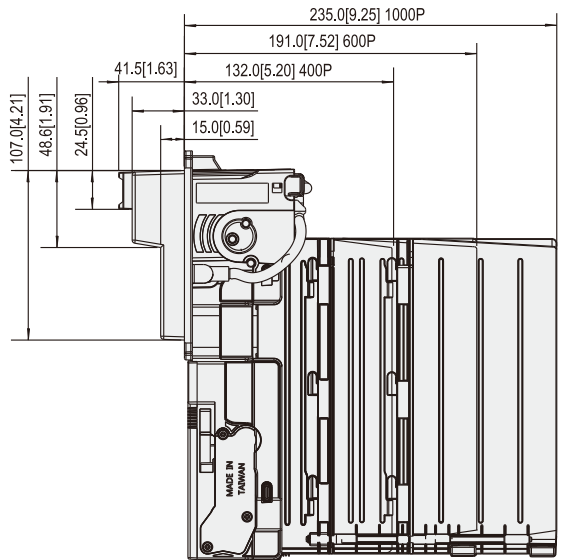
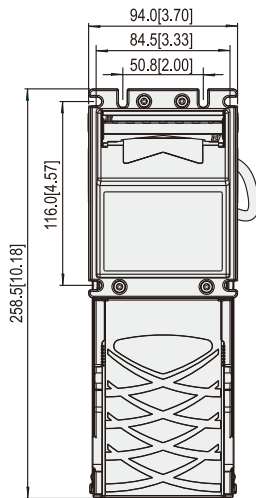

Unit : mm [inch]

4 FIG.03

5. Installation

5-1. Harness Application

5-1 TABLE 01

Interface	Used Voltage	Usage	Harness	Page
MDB	24V/34VDC	Power & *Data comm.	WEL-RM006	7
	24VAC			
Pulse	12V/24VDC	Power & *Data comm.	WEL-RV701	8
		Extension Wire	CU-R961-1	8
	24VAC	Power & *Data comm.	WEL-RV703	9
		Extension Wire	WEL-RV702	9
ICT Protocol	12V/24VDC	Power	WEL-RV701	8
		Extension Wire	CU-R961-1	8
		*Data Comm.	WEL-RV706-1 or 2-BA-RV706	10
JPSTD	24VDC	Power & *Data Comm.	WEL-RX7P03	11
USB Download	-	USB Extension Wire	WEL-RX7P02-1	11

*Date Comm.:Data Communication.

5-1 FIG.01

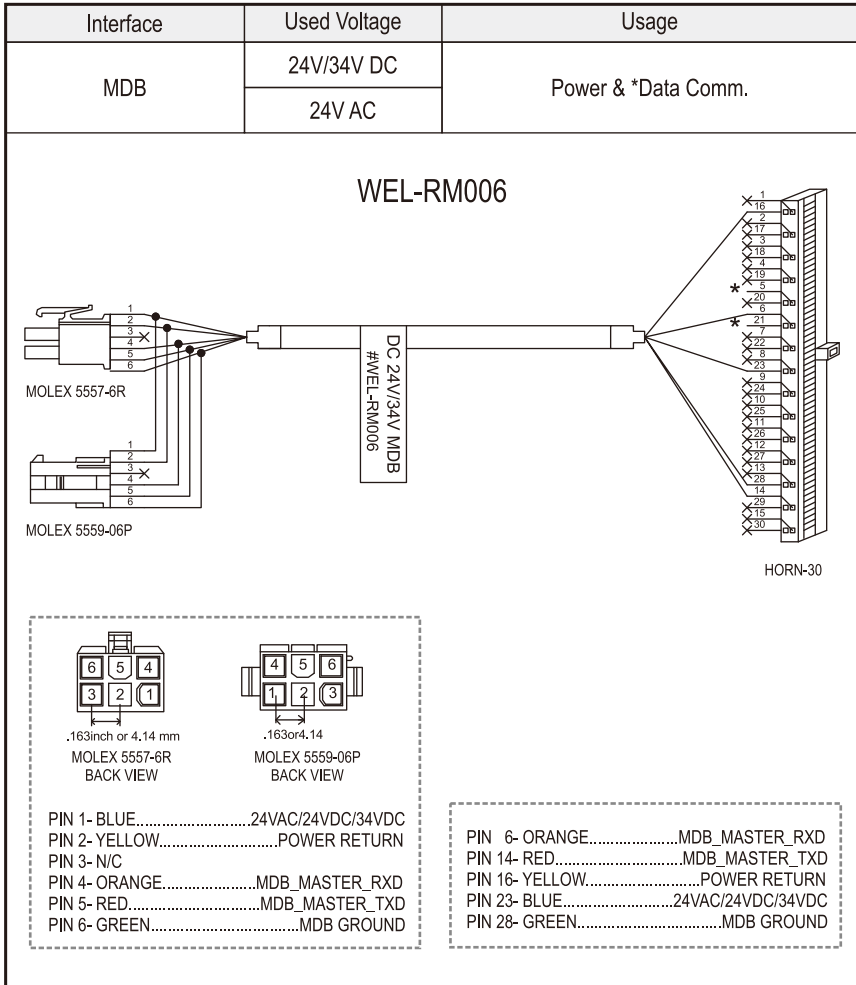

5-1 FIG.02

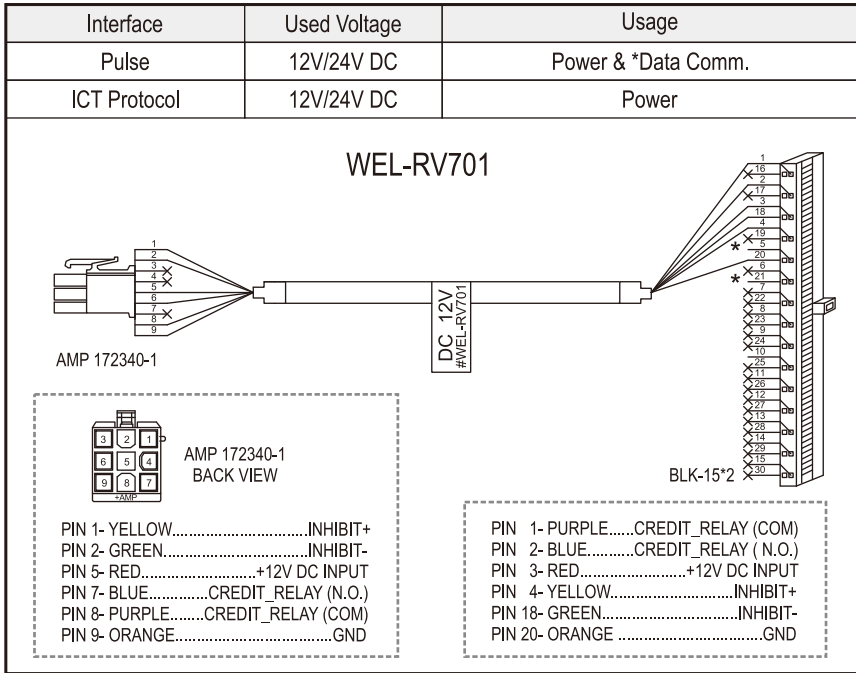

5-1 FIG.03

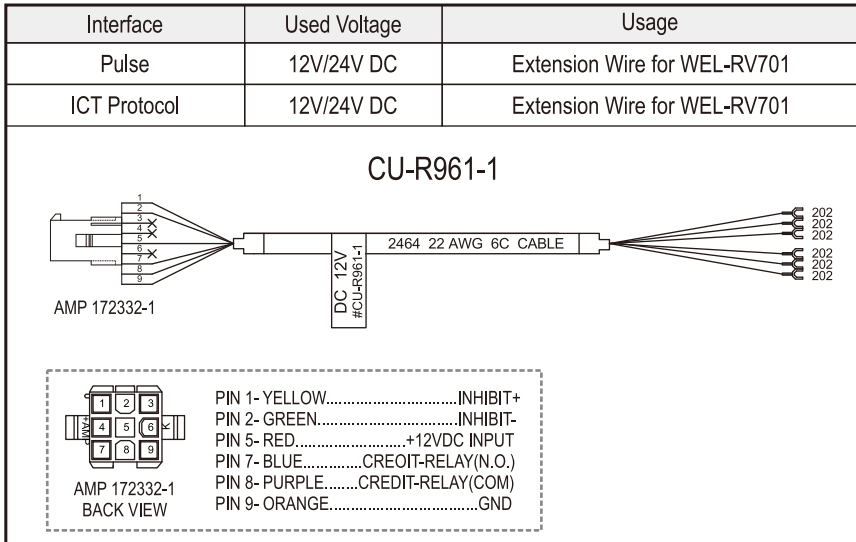

5-1 FIG.04

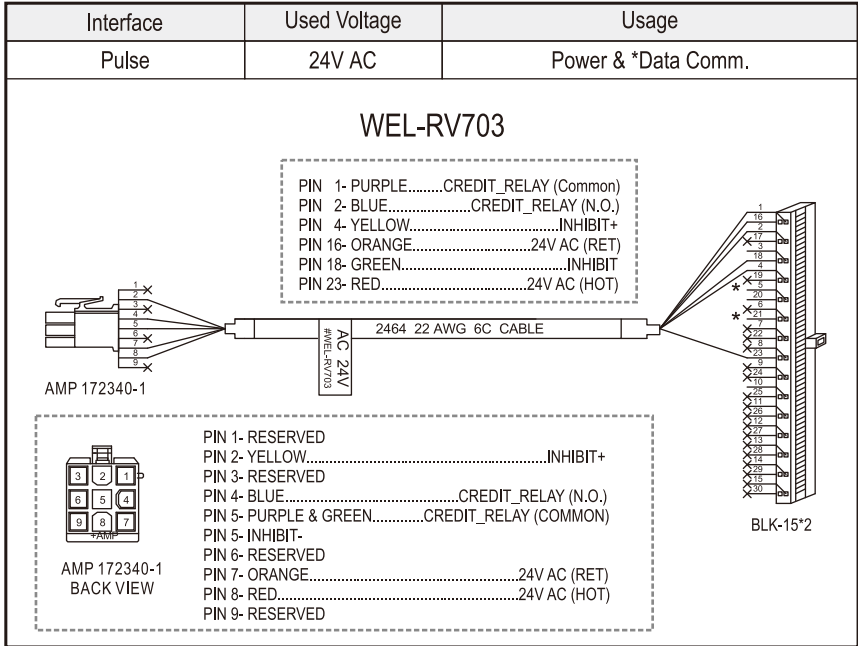

5-1 FIG.05

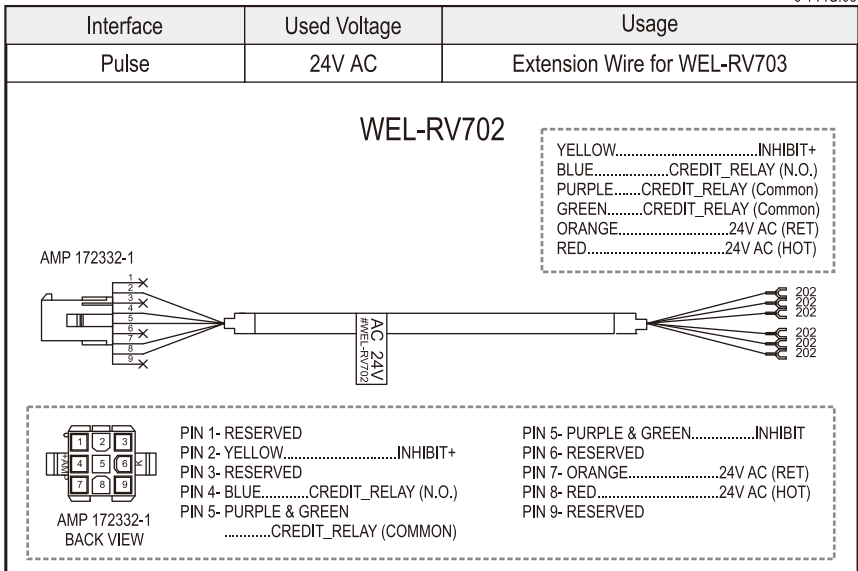

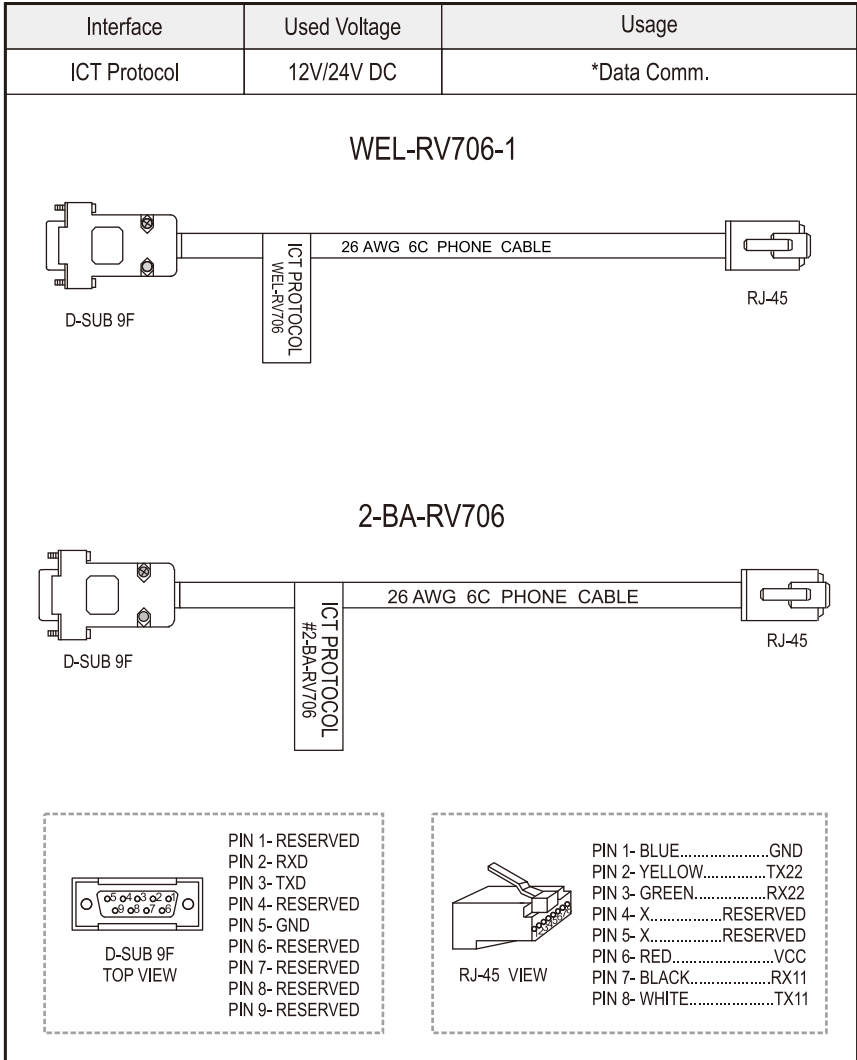

5-1 FIG.07

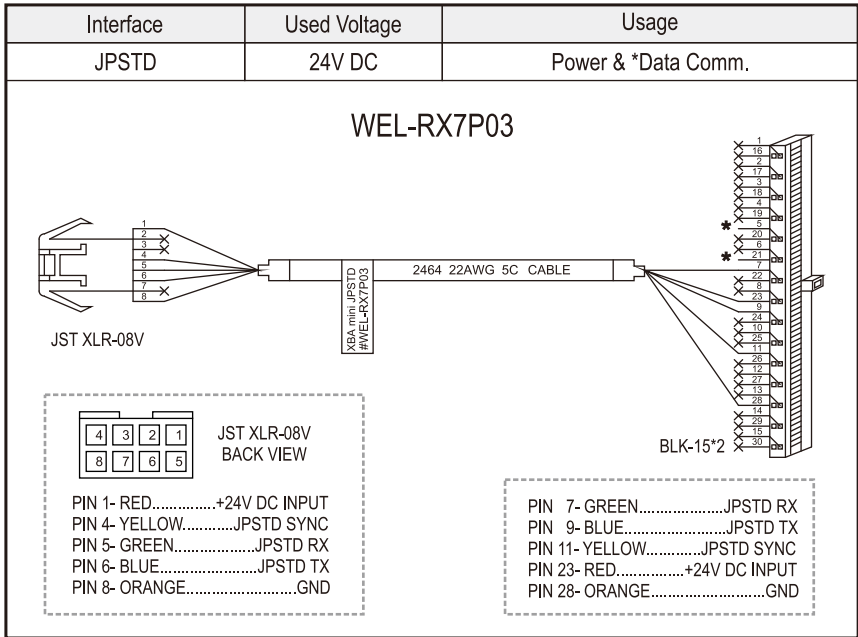

5-1 FIG.08

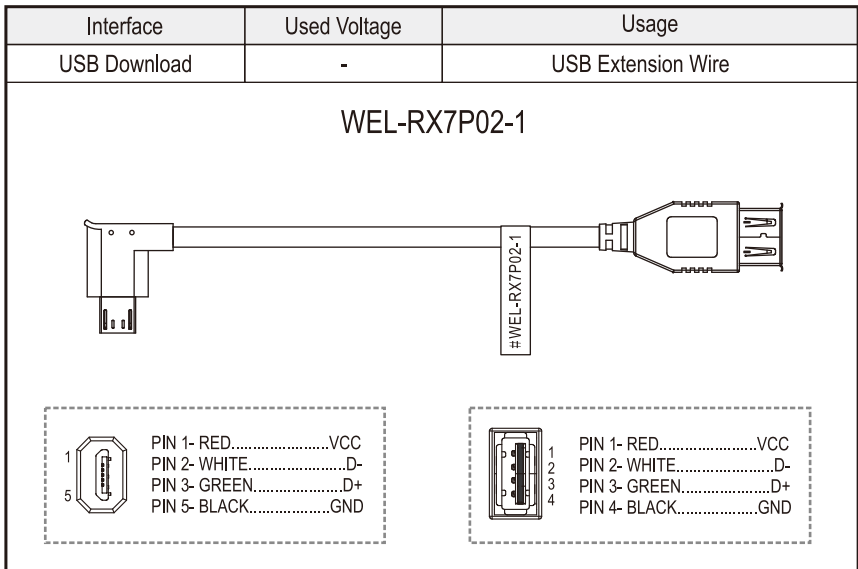

5-1-1. I/O Circuit

Pulse Interface.

5-1-1 FIG.01

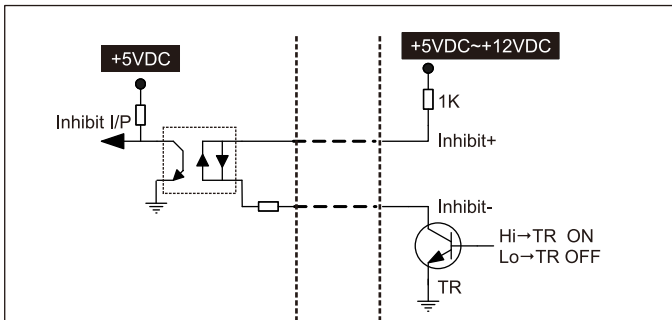
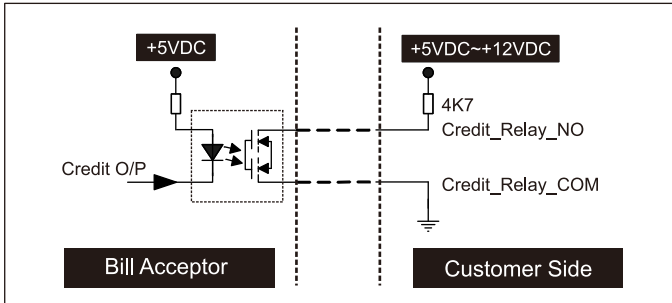

BA Status	DIP SW Setting		Control Signal
Inhibit	Inhibit Active	Low	Low
		High	High
Enable	Inhibit Active	Low	High
		High	Low

ICT-Protocol Interface.

5-1-1 FIG.02

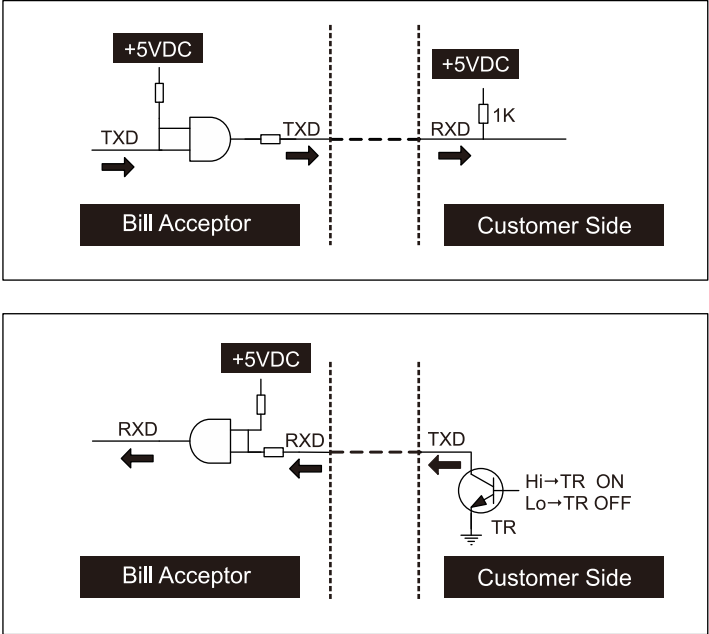

MDB Interface.

5-1-1 FIG.03

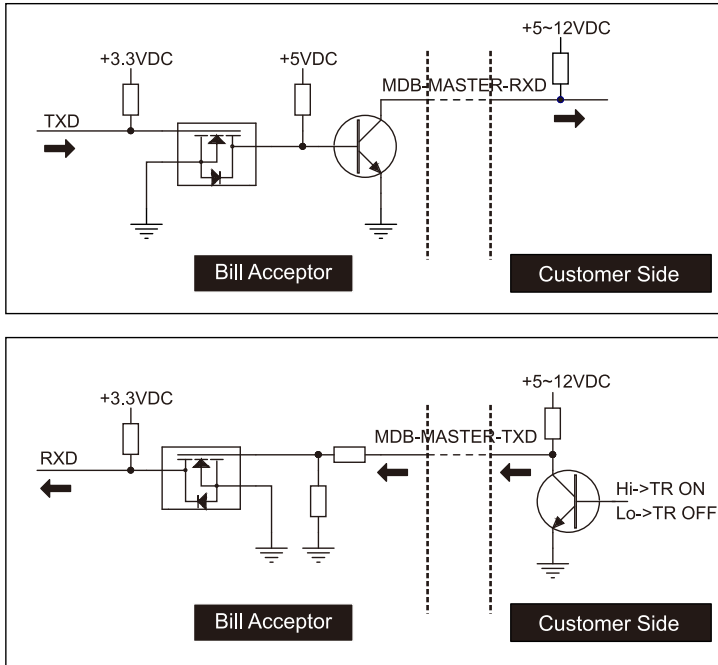

JPSTD Interface.

5-1-1 FIG.04

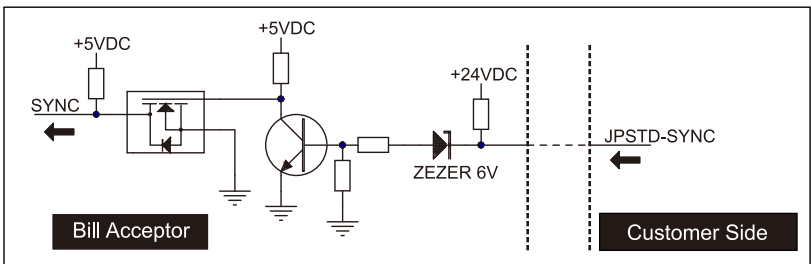
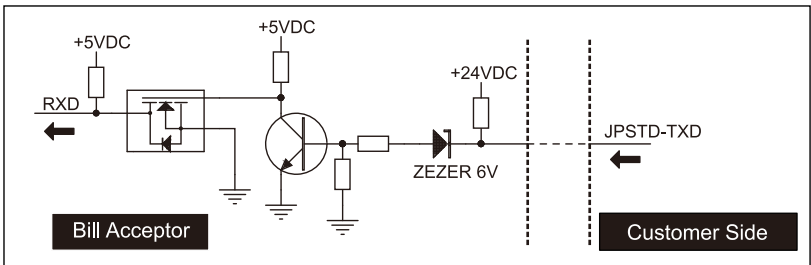
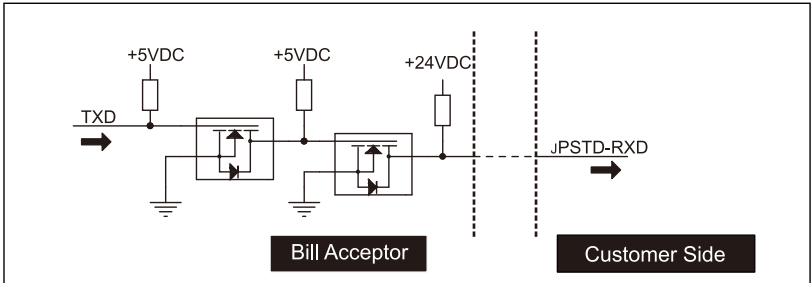

5-2. DIP Switch Setting

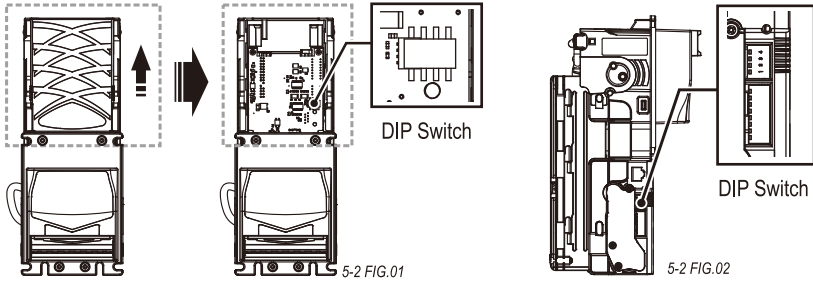

Two dip switches are located on as FIG.01 the CPU board, and as FIG.02 the sides of XBA-mini series.

5-3. Firmware Download and Upgrade

Step 1.

Put the "X7Exxx.bin" file into your USB Pen Drive.



PC



USB Pen Drive

Step 2.

Turn off XBA-mini, plug the USB Pen Drive into the USB connector on the XBA-mini and then turn on the XBA-mini.

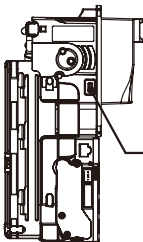

XBA-mini



USB Pen Drive

Step 3. The LED in the rear side of bill insertion module will flash twice, then remove the USB Pen Drive from XBA-mini.

Step 4. Wait for about 30sec., Then XBA-mini will automatically reset and standby for normal operation.

6. Maintenance

To make sure the bill acceptor always works smoothly, please clean the internal parts regularly.

To clean the internal parts:

1. Press the buttons on the sides of bill path and pull the unit out.

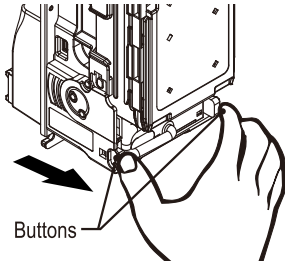

6 FIG.01-1

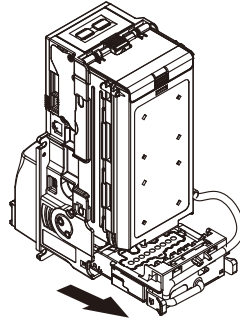

6 FIG.01-2

2. Use a soft, dry cloth or towel to clean the bill path and sensors.

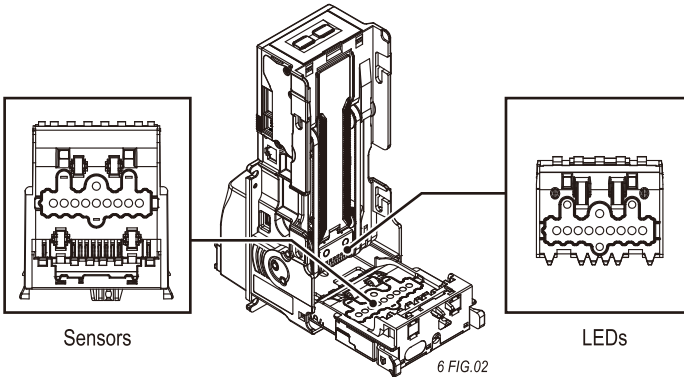

6 FIG.02



Maintenance Notice
(Any improper maintenance will result invalid warranty.)

Recommended	Mild, non-abrasive, soap water.
DO NOT USE	Organic solvent , Alcohol, Volatility liquid.

7. Troubleshooting

7-1. Bezel LED Errors

7-1 TABLE.01

LED Flashes		Status	Corrective Actions
RED	GREEN		
	1	White Card Calibration	Please calibrate with ICT white calibration card.
1		Bill jammed.	Remove the bill box by sliding the top button and the bill path(as 7-2 FIG.01), and then remove the jammed bill.
2		Disable.	Inspect the right DIP switch setting.
3		Recognition sensor module error.	Inspect the foreign objects on sensor or bill path and clean.
3	1	IR error.	Inspect the foreign objects on sensor or bill path and clean.
3+2		Hook sensor error.	Inspect the foreign objects on security hook and clean.
4		Anti-string sensor error or a stringing attempt has detected.	Inspect the foreign objects on sensor or bill path and clean.
5		Bill box has been removed.	Replace the bill box.
6		Stacker error or stacker full.	Empty the bill box.
7		Motor error.	Inspect the foreign objects on bill path and clean.

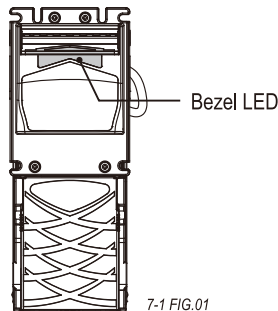

If the error can not be solved after corrective actions or happen again, please contact ICT for technical support.

7-2. Back LED Errors

7-2 TABLE.01

LED Flashes	Status	Corrective Actions
RED		
1	White Card Calibration	Please calibrate with ICT white calibration card.
1	Bill jammed.	Remove the bill box by sliding the top button and the bill path(as 7-2 FIG.01), and then remove the jammed bill.
2	Disable.	Inspect the right DIP switch setting.
3	Recognition sensor module error.	Inspect the foreign objects on sensor or bill path and clean.
3+1	IR error.	Inspect the foreign objects on sensor or bill path and clean.
3+2	Hook sensor error.	Inspect the foreign objects on security hook and clean.
4	Anti-string sensor error or a stringing attempt has detected.	Inspect the foreign objects on sensor or bill path and clean.
5	Bill box has been removed.	Replace the bill box.
6	Stacker error or stacker full.	Empty the bill box.
7	Motor error.	Inspect the foreign objects on bill path and clean.

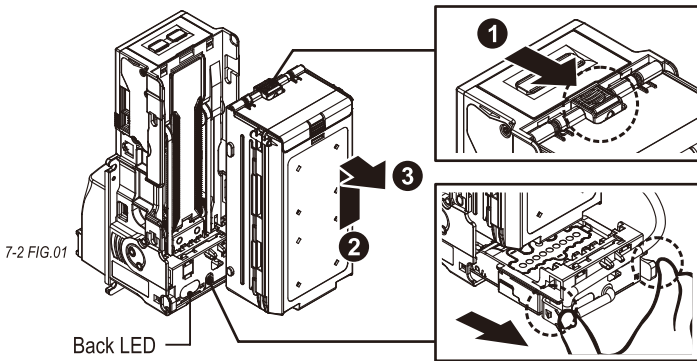

If the error can not be solved after corrective actions or it recurs, please contact ICT for technical support.

ict Taiwan

International Currency Technologies Corporation

No.28, Ln. 15, Sec. 6, Minquan E. Rd., Neihu Dist., Taipei City 114, Taiwan

sales@ictgroup.com.tw (For Sales)

fae@ictgroup.com.tw (For Customer Service)

Website: www.ictgroup.com.tw

